

CHRONO 28

NF E 52081 - E 52082

DIN 15018 H1 B3 K3



Cotes

Abmessungen

Dimensions

Dimensiones

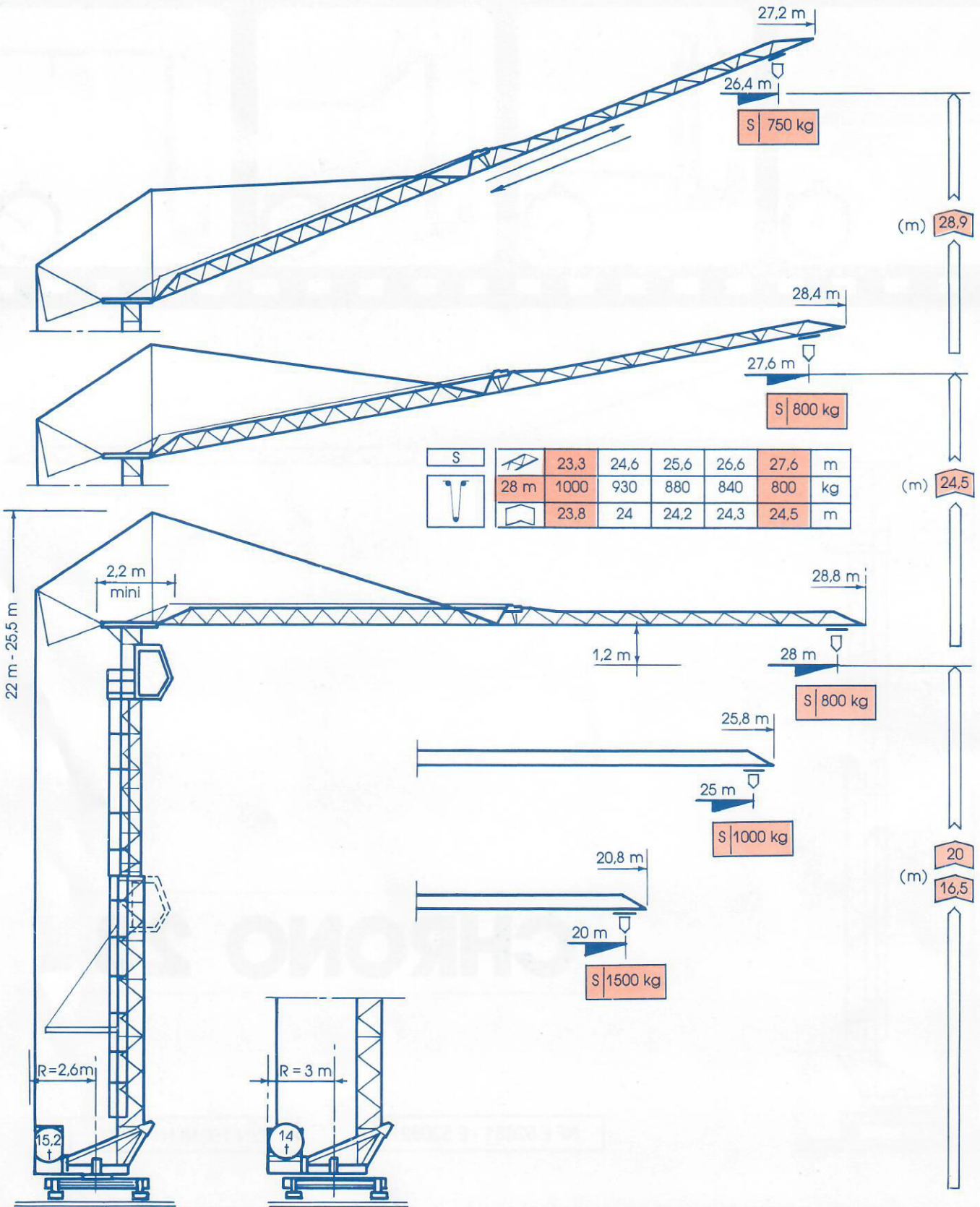

18,7 t
EN SERVICE
IN BETRIEB
IN SERVICE
EN SERVICIO

9,1 t
A VIDE SANS LEST NI TRAINS DE TRANSPORT
OHNE LAST, BALLAST UND TRANSPORTACHSE
WITHOUT LOAD, BALLAST OR TRANSPORT AXLES
VACIO, SIN LASTRE NI TREN DE TRANSPORTE

CHRONO 28

S		10	10,5	11	11,5	12	13	15	17	18	20	21	23	25	26	27	28 m	
		28 m	3000	2800	2640	2500	2360	2130	1770	1510	1410	1230	1160	1030	930	880	840	800
		25 m		3000	2830	2670	2530	2280	1900	1630	1510	1330	1250	1110	1000			
		20 m			3000	2840	2560	2140	1830	1710	1500							kg

Courbes de charges

Lastkurven

Load curves

Curvas de cargas

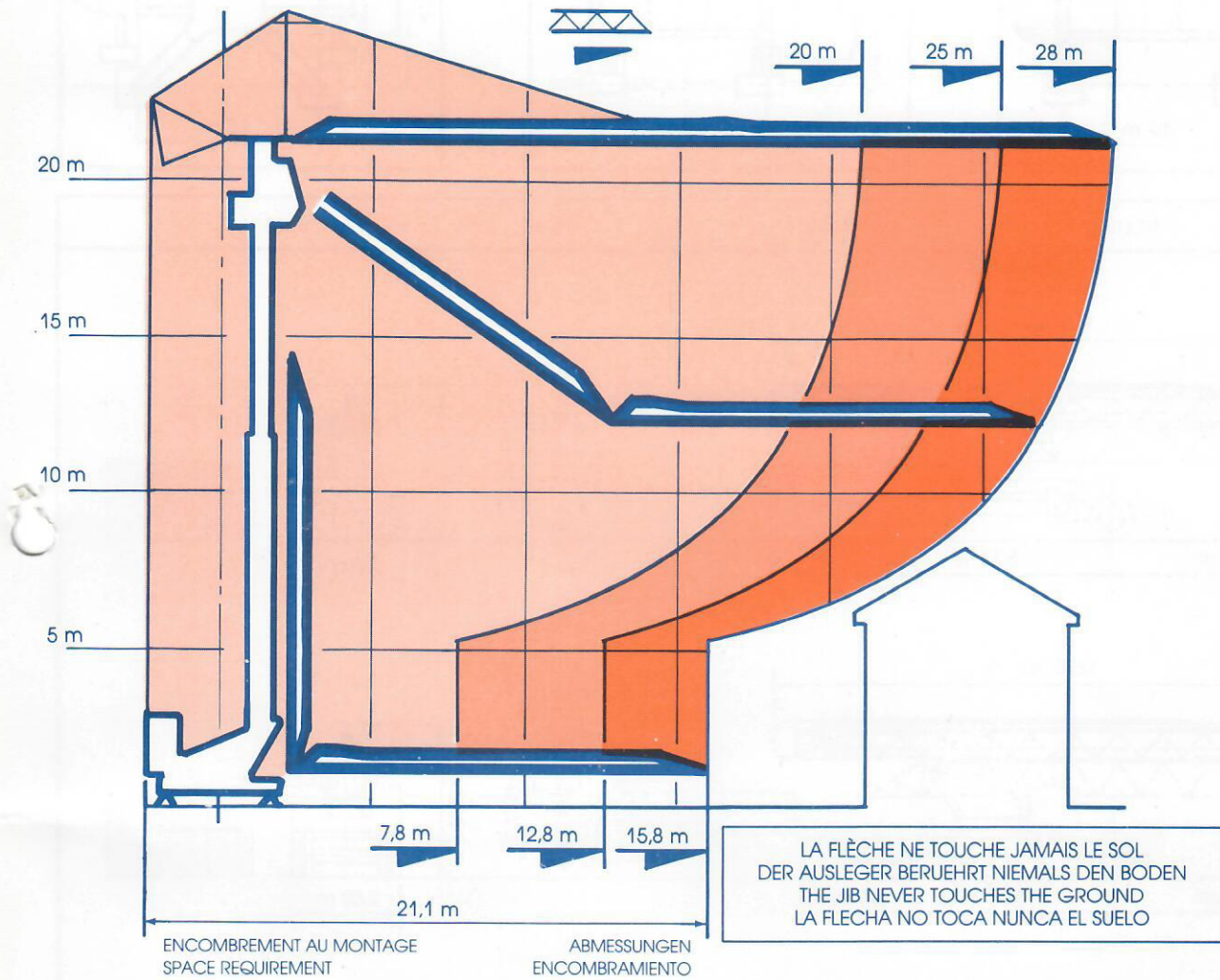

GROUPE ELECTROGENE NOUS CONSULTER
 STROMAGGREGAT AUF ANFRAGE
 GENERATOR SET CONSULT US
 GRUPO ELECTROGENO CONSULTARNOS

CHRONO 28	m/mn *	KW *	ch PS-HP *	kg				
	I	3,8	2,2	3	3000	V	380	450
	II	18	11	15	3000	Hz	50	60
	III	36	11	15	1500	kVA	20	24
tr/mn U/mn Rpm V/mn	35	2,2	3		* Multiplier par 1,2 pour 450 V Multiplizieren bei 1,2 für 450 V Multiply by 1,2 for 450 V Multiplicar por 1,2 para 450 V			
	0 > > 35	2,2	3					
	0 > > 30	2 x 0,75	2 x 1					

Versions sur chassis

Unterwagen

Undercarriage

Chassis

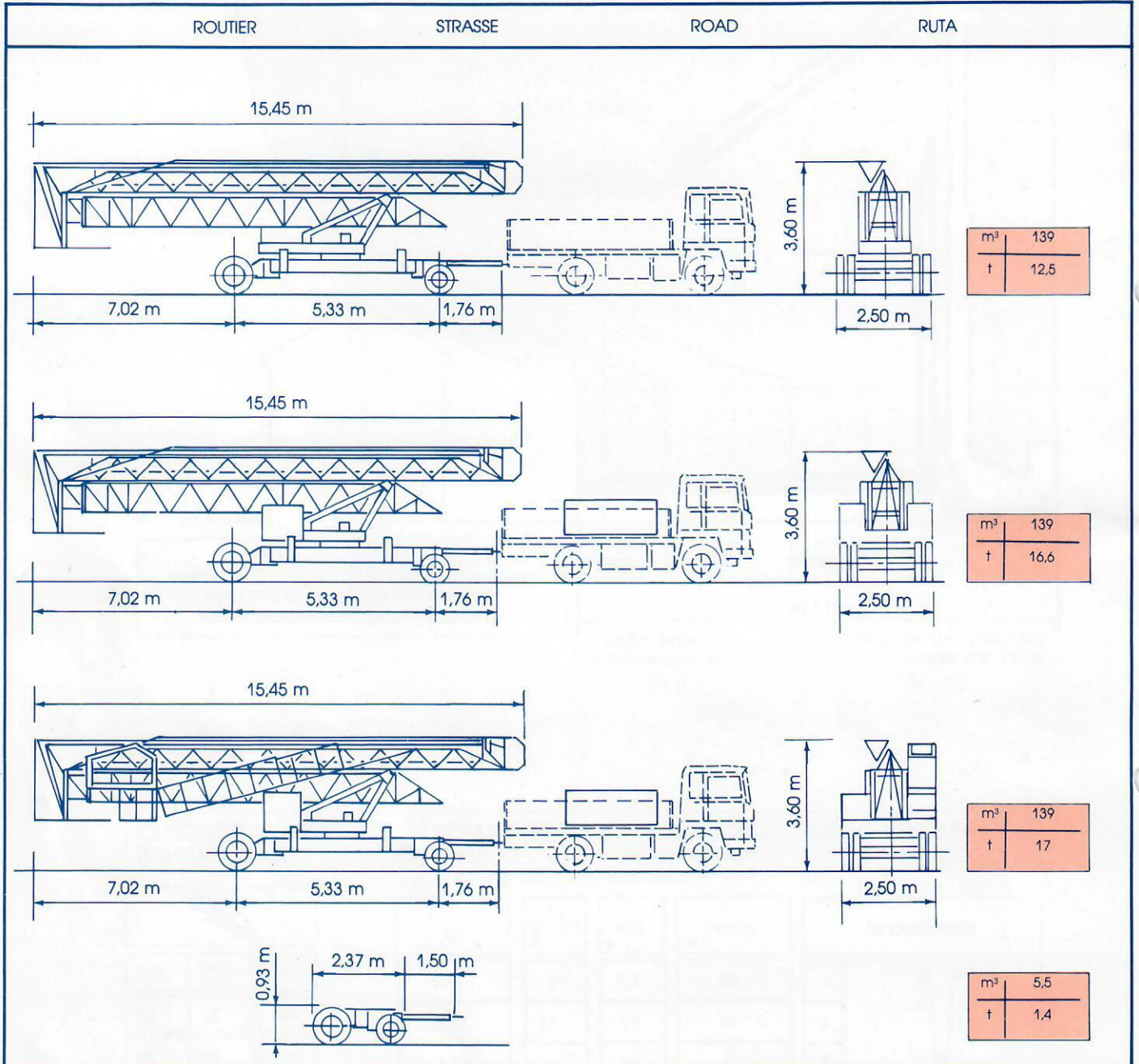
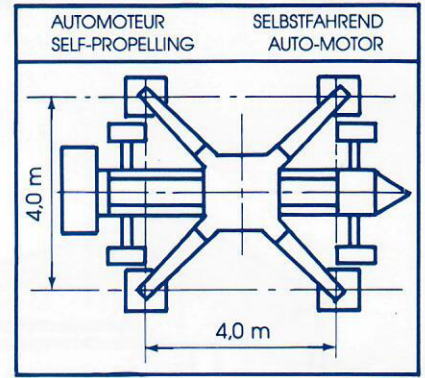
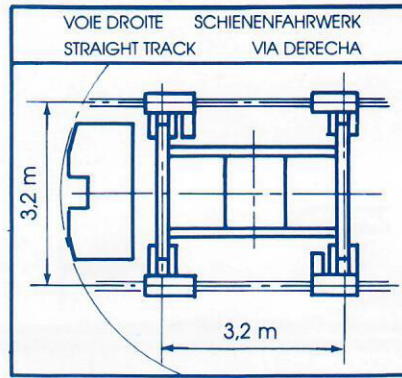
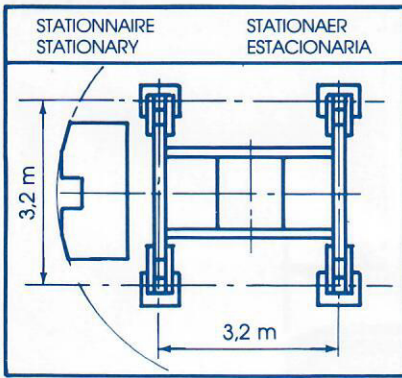

Transport

Transport

Transport

Transporte



CADILLON INDUSTRIE
8, rue de Pretin - B.P. 25 - F 71120 CHAROLLES - FRANCE
Tél. 85 24 09 34 - Télex 800418

Filiale - Subsidiary - Filiale - Sucursal :

CADILLON BAUMASCHINEN G.m.b.h. - Waldstr. 6
D - 6108 WEITERSTADT - W. GERMANY
Tél. (19.49) 6151.85051. - Télex 419 223

CADILLON BAUMASCHINEN A.G.
Hofstr. 15 - CH - 8181 HÖRI
Tél. 01.861.15.65. - Télex 825 996

