

# CHRONOFLASH® 35

NF E 52081 - E 52082

DIN 15018 H1 B3 K3

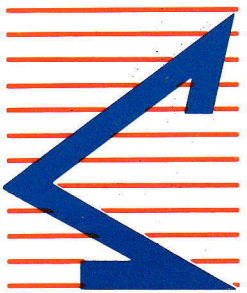

# CADILLON



**Cotes**

**Abmessungen**

**Dimensions**

**Dimensiones**

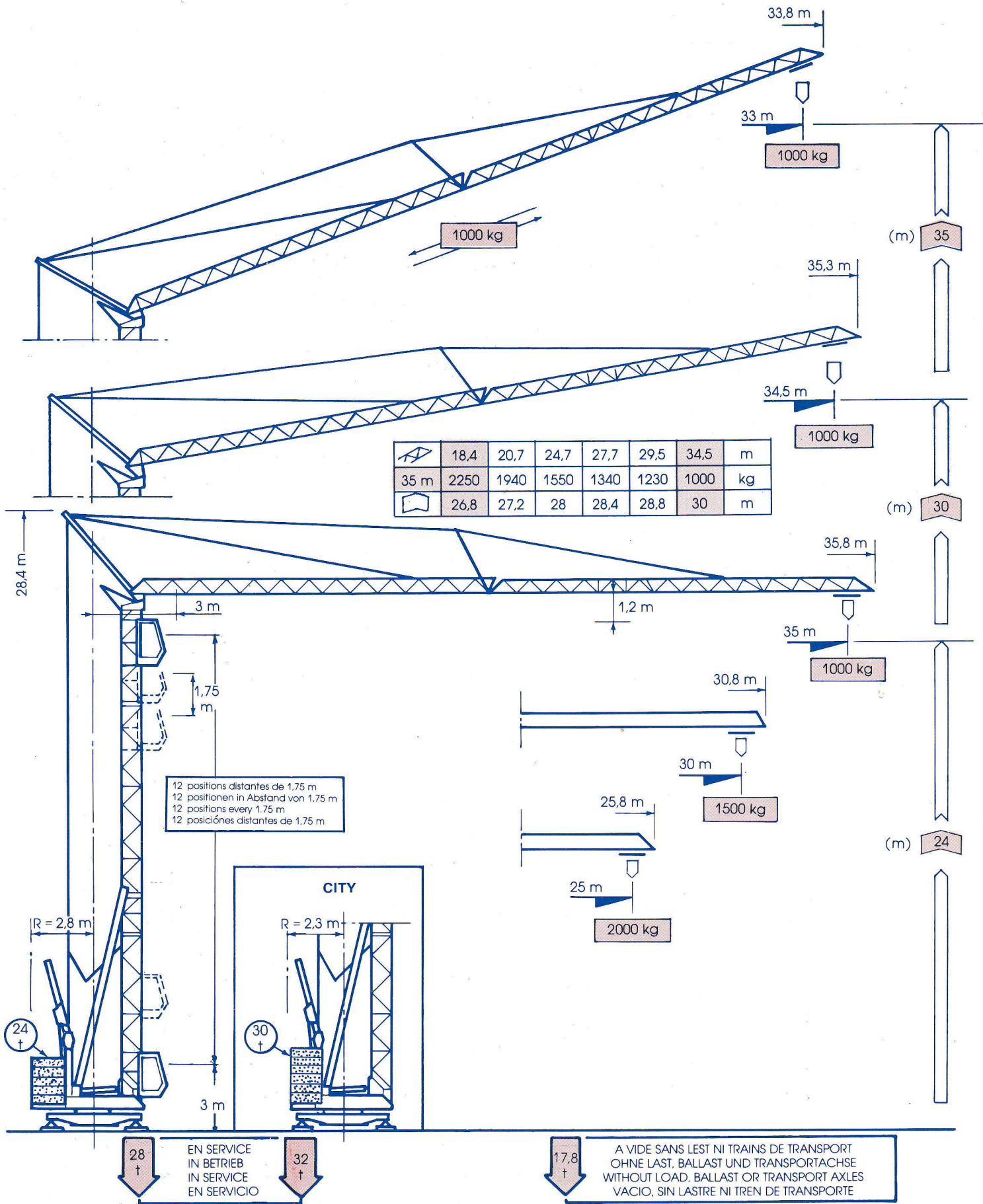

**CHRONOFLASH 35**

S/D		10,9	12,5	13	14	15	16	17	18	20	21	23	25	28	30	33	35 m
	35 m	4500	3760	3580	3250	2980	2740	2540	2360	2070	1940	1730	1550	1340	1230	1080	1000
	30 m		4500	4290	3900	3570	3290	3050	2840	2490	2350	2100	1890	1640	1500		
	25 m			4500	4120	3770	3480	3230	3000	2640	2480	2220	2000				kg

**Courbes de charges**

**Lastkurven**

**Load curves**

**Curvas de cargas**

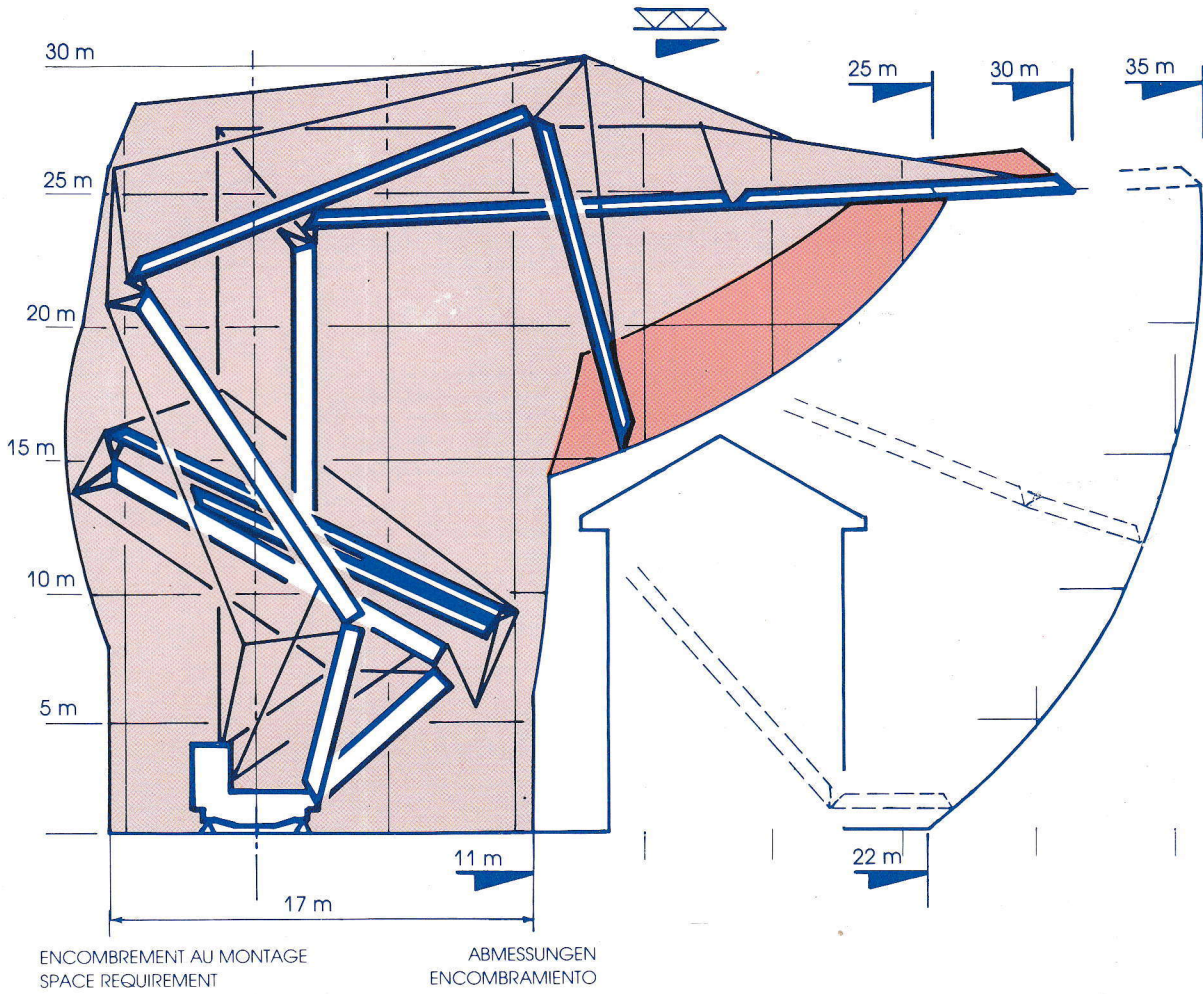

CHRONOFASH 35		m/mn *	KW *	ch PS - HP *	kg
	I	3	4	5,5	4500
	II	12,5	11	15	4500
	III	25	15	20 *	3000
	I	6	4	5,5	2250
	II	25	11	15	2250
	III	50	15	20	1500
		0,15 > 0,4 > 0,8	4	5,5	
	I	22,5	4	5,5	
	II	45			
		0 > > 25	2 x 2,2	2 x 3	

V	380	450
Hz	50	60
kVA	25	30

- GROUPE ELECTROGENE  
NOUS CONSULTER  
- STROMAGGREGAT  
AUF ANFRAGE  
- GENERATOR SET  
CONSULT US  
- GRUPO ELECTROGENO  
CONSULTARNOS

\*

Multiplier par 1,2 pour 450 V  
Multiplizieren bei 1,2 für 450 V  
Multiply by 1,2 for 450 V  
Multiplicar por 1,2 para 450 V

## Versions sur chassis

## Unterwagen

## Undercarriage

## Chasis

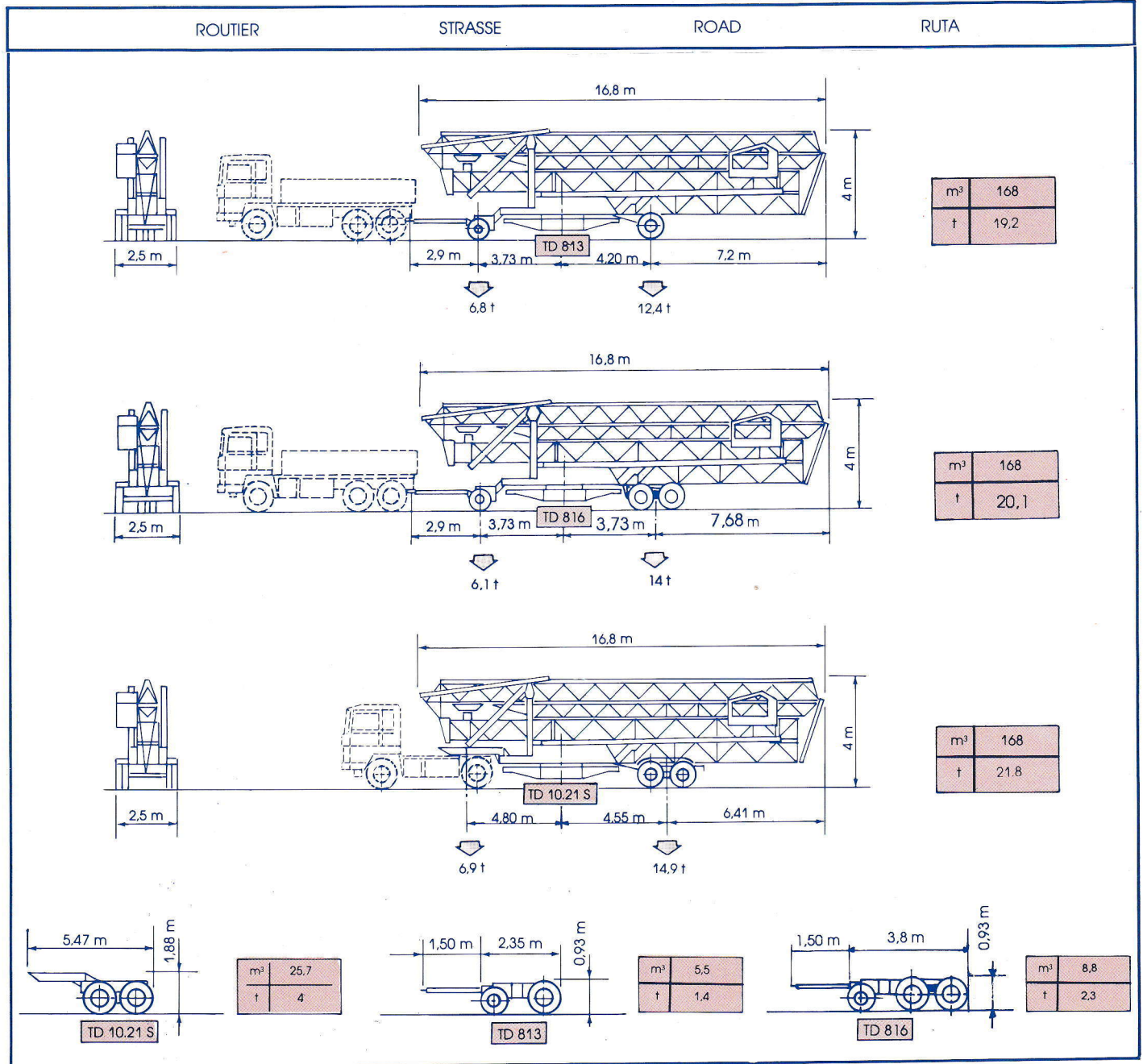
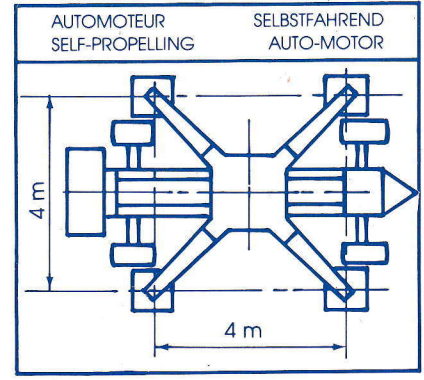
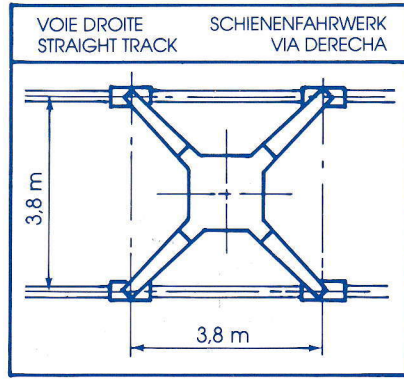
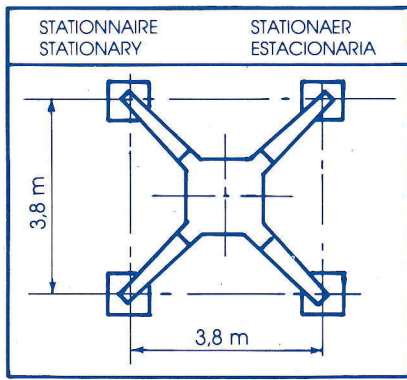

## Transport

## Transport

## Transport

## Transporte



# CADILLON

CADILLON INDUSTRIE : 8, rue de Pretin - B.P. 25 - F 71 120 CHAROLLES - FRANCE  
Tél. 85 24 09 34 - Téléx 800 418 - Télécopie 85 88 34 10

Filiale - Subsidiary - Filiale - Sucursal :

CADILLON BAUMASCHINEN G.m.b.h. : Am Dornbusch 4 - D 6108 WEITERSTADT  
R.F.A. - Tél. 19 49 6151 85041 ou 85042 ou 85043  
Télécopie 19 49 6151 82535 - Telex 041419223 +

CADILLON U.S.A. Inc. : 5777 West Century Boulevard - Suite 520 - LOS ANGELES  
CALIFORNIE 90045 - Tel. 19.1.213.216.0060 - Télécopie 19.1.213.410. 1017